

Ecology

Energy Saving

Excellent Pump

● **Highly efficient pumps can save the energy consumption!**
Simple choice from simple product line

● **Silent Running! Environmentally friendly**
(Approx. 67dB (A) from 2 MPa, 30 l/min)

Note) Simplified Pump data

● **Ultra-compact, space-saving**



High Durability and Maintenance-free

In addition to the simple structure, high-pressure coolant fluid automatically lubricate the friction surface of all the parts, thereby allowing no direct contact between parts and even longer lasting.

Furthermore E3P pump adopt built-in relief valves, no need to add it.

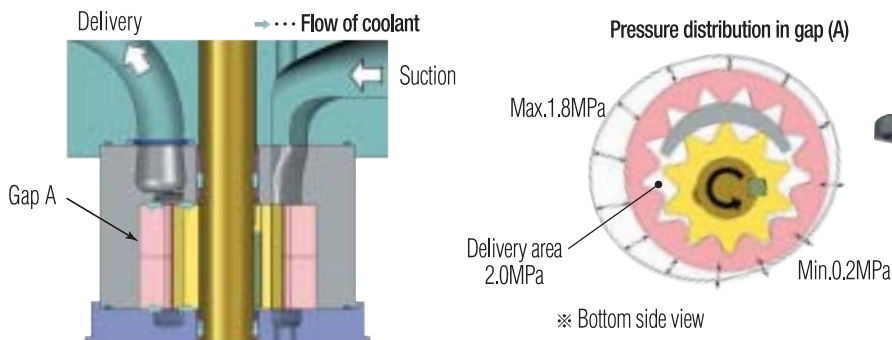

Model Number

E3P-16-1.5

Basic model

Theoretical displacement
(cc/rev)

Motor rating

Pump Lineup

Model No.	pressure (max.)	Delivery (l/min)		Power input (kW)	
		50Hz	60Hz	50Hz	60Hz
E3P-10	2.0MPa	9	12	0.6	0.8
E3P-12.5		13	16	0.8	1.0
E3P-16		16	21	1.0	1.2
E3P-20		20	26	1.3	1.6
E3P-25		27	34	1.6	2.0
E3P-31.5		34	44	2.0	2.5

● Non water-base (oil-base) coolant

E3P pumps are also designed to use non water-base coolant fluid. Please contact us with oil-base coolant viscosity (cSt) and its brand information.

Performance Chart

Synchronous rotation speed 1500 min⁻¹ E3P (50 Hz)

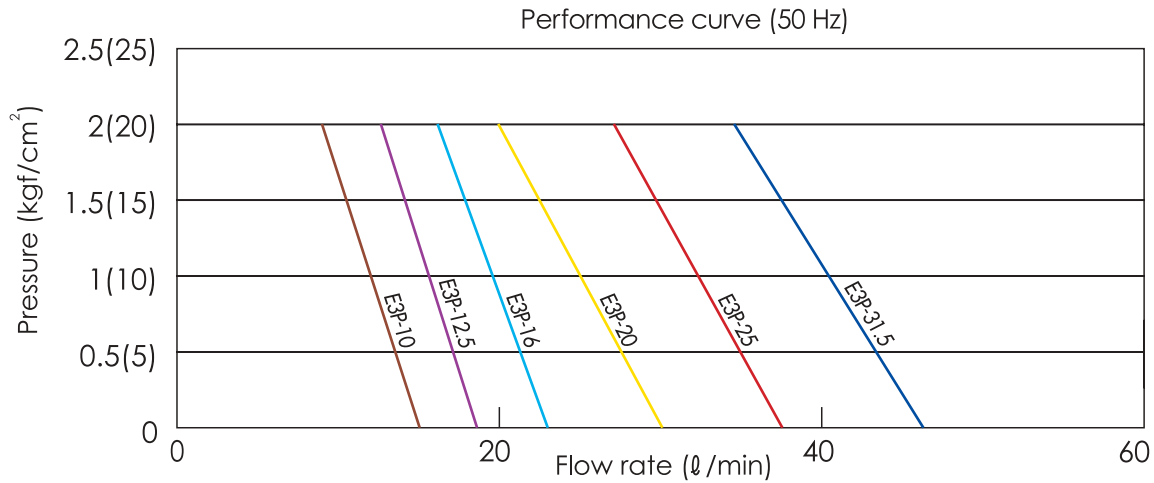

50Hz

Model No.		E3P-※-1.5			E3P-※-2.2		
Pressure	Flow rate	-10	-12.5	-16	-20	-25	-31.5
0MPa	(ℓ/min)	15	19	23	30	38	47
1.0MPa	(ℓ/min)	12	15	19	25	32	40
Shaft input power	kW	0.4	0.5	0.6	0.8	0.9	1.2
2.0MPa	(ℓ/min)	9	13	16	20	27	34
Shaft input power	kW	0.6	0.8	1.0	1.3	1.6	2.0

Synchronous rotation speed 1800 min⁻¹ E3P (60 Hz)

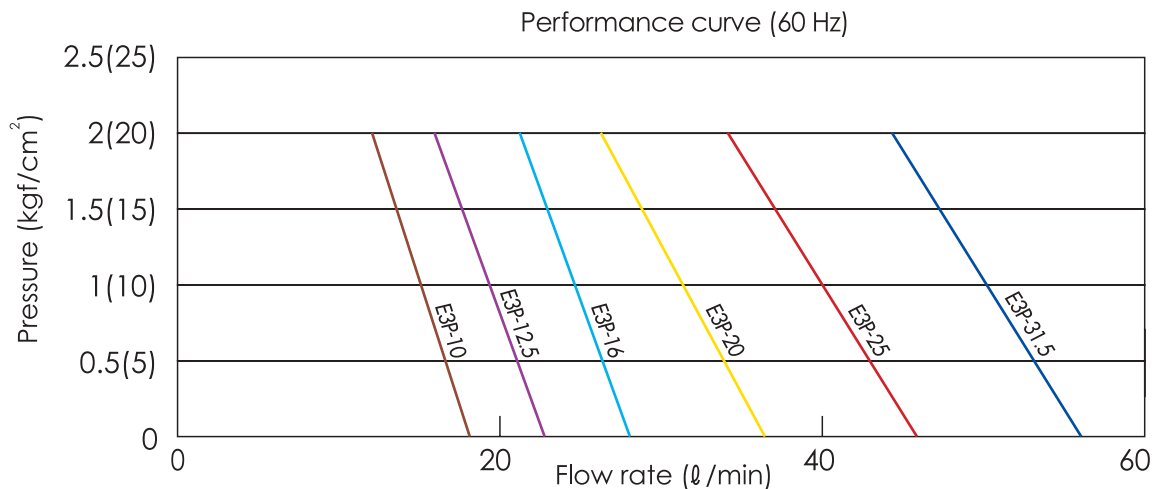

60Hz

Model No.		E3P-※-1.5			E3P-※-2.2		E3P-※-3.7
Pressure	Flow rate	-10	-12.5	-16	-20	-25	-31.5
0MPa	(ℓ/min)	18	23	28	36	45	56
1.0MPa	(ℓ/min)	15	19	24	31	39	50
Shaft input power	kW	0.5	0.6	0.7	0.9	1.2	1.5
2.0MPa	(ℓ/min)	12	16	21	26	34	44
Shaft input power	kW	0.8	1.0	1.2	1.6	2.0	2.5

Dimensions Drawing

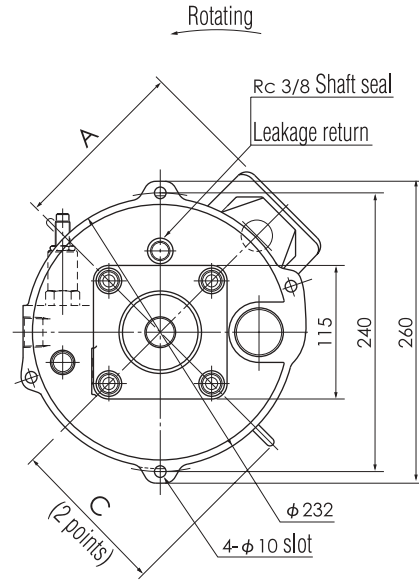
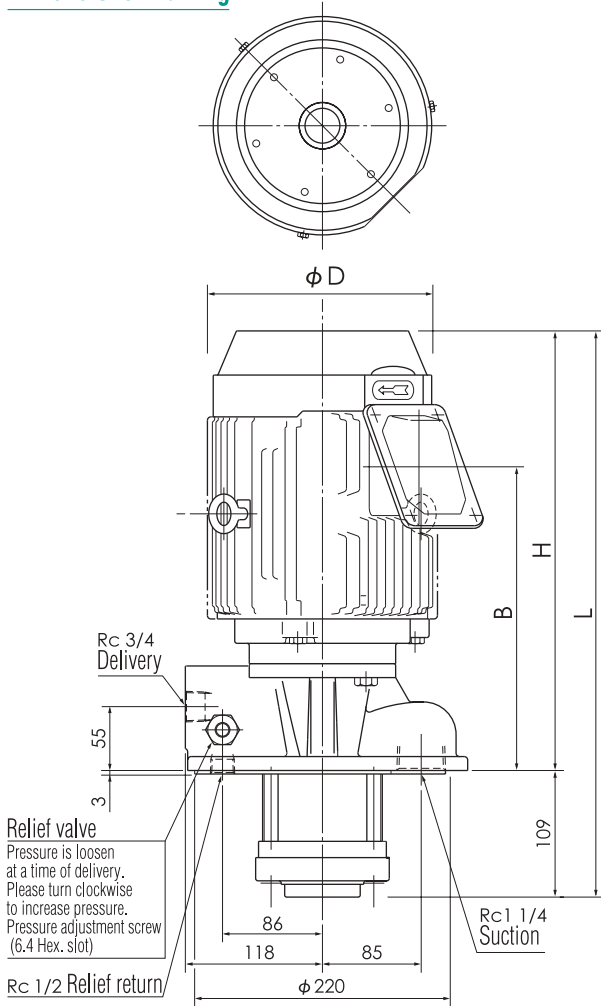

Dimensional data

Model No.	Motor	A	B	C	D	H	L	Weight (kg)
E 3 P	1.5kW	153	232.5	137	198	350	459	37
	2.2kW	153	261.5	137	198	379	488	43
	3.7kW	164	312.5	148	214	448	557	50

Suction / Relief Return / Delivery Piping Flanges (Not included in pump package)

● Model of suction piping

Model	Size
PS-L	350mm
PS-S	250mm

● Model of relief return piping

Mode	Size
PR-L	350mm
PR-S	250mm

● Model of delivery piping flange EF-06 (Rc 3/4)

※Suction pipes can be threaded into pumps without this flange.

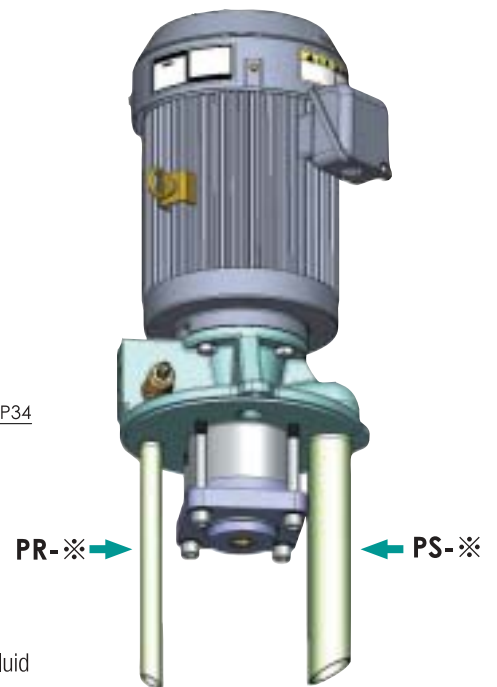
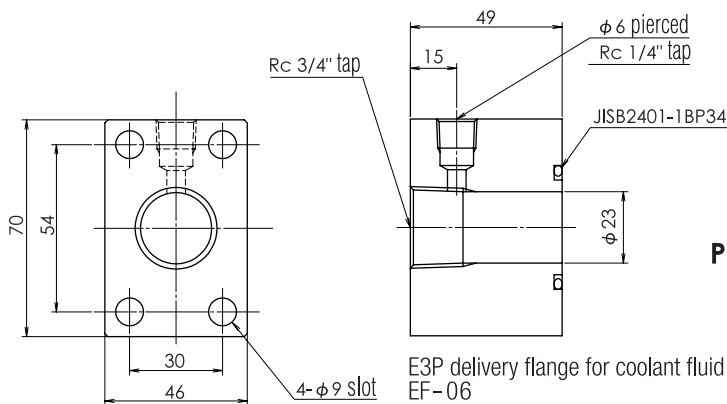

Configuration

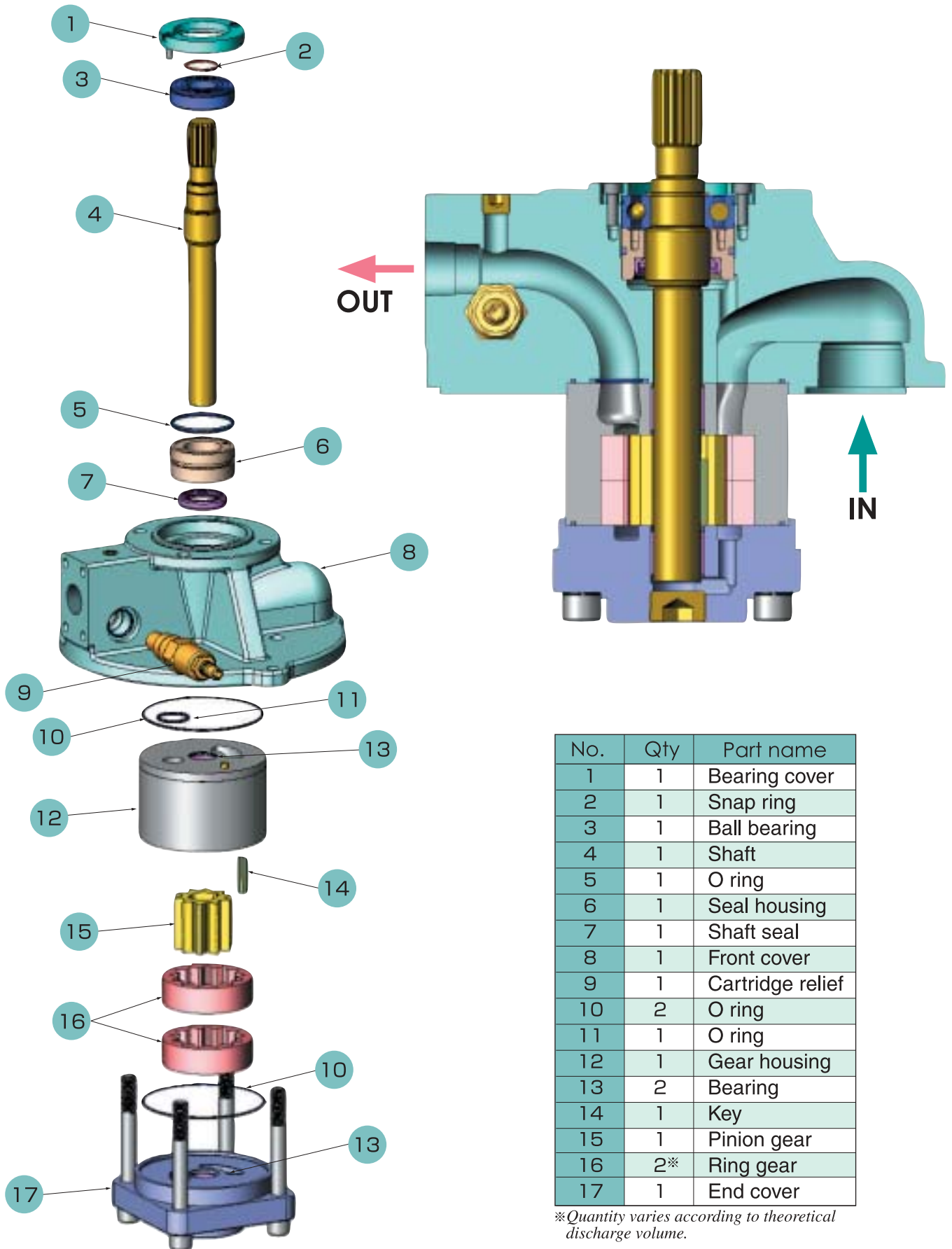

No.	Qty	Part name
1	1	Bearing cover
2	1	Snap ring
3	1	Ball bearing
4	1	Shaft
5	1	O ring
6	1	Seal housing
7	1	Shaft seal
8	1	Front cover
9	1	Cartridge relief
10	2	O ring
11	1	O ring
12	1	Gear housing
13	2	Bearing
14	1	Key
15	1	Pinion gear
16	2*	Ring gear
17	1	End cover

*Quantity varies according to theoretical discharge volume.

Motor Current Value

● **Directly Coupled Type** [Unit : A]

Capacity	Voltage / Frequency	With 100% load
1.5 kW	200V/50Hz	7.00
	200V/60Hz	6.20
	220V/60Hz	6.00
	380V/50Hz	3.70
2.2 kW	200V/50Hz	9.80
	200V/60Hz	8.90
	220V/60Hz	8.50
	380V/50Hz	5.20
3.7 kW	200V/50Hz	16.0
	200V/60Hz	14.8
	220V/60Hz	14.0
	380V/50Hz	8.50
5.5 kW	200V/50Hz	23.8
	200V/60Hz	21.0
	220V/60Hz	20.0
	380V/50Hz	12.5
7.5 kW	200V/50Hz	31.8
	200V/60Hz	28.2
	220V/60Hz	27.0
	380V/50Hz	16.7

● **Bell Flange Type** [Unit : A]

Capacity	Voltage / Frequency	With 100% load
5.5 Kw	200V/50Hz	21.5
	200V/60Hz	20.6
	220V/60Hz	19.2
	380V/50Hz	11.1
7.5 Kw	200V/50Hz	28.7
	200V/60Hz	27.6
	220V/60Hz	25.5
	380V/50Hz	14.8
11.0 Kw	200V/50Hz	41.8
	200V/60Hz	39.7
	220V/60Hz	37.0
	380V/50Hz	21.4
15.0 Kw	200V/50Hz	55.4
	200V/60Hz	52.9
	220V/60Hz	49.3
	380V/50Hz	28.4
18.5 Kw	200V/50Hz	67.0
	200V/60Hz	65.1
	220V/60Hz	59.8
	380V/50Hz	34.7
22.0 Kw	200V/50Hz	80.2
	200V/60Hz	77.3
	220V/60Hz	71.6
	380V/50Hz	41.3
30.0 Kw	200V/50Hz	108.0
	200V/60Hz	104.0
	220V/60Hz	96.1
	380V/50Hz	55.7

Micron VS. Mesh Conversion Table

Mesh	150	170	200	250	270	300	500	600	800	1000	1450
Micron(μm)	100	88	75	60	53	50	30	25	20	15	10

Nozzle dia. VS. Pressure

Nozzle dia. φx2	Nozzle outlet pressure MPa(kgf/cm ²)							
	6.9(70)	5.9(60)	4.9(50)	3.9(40)	2.9(30)	2.0(20)	1.5(15)	1.0(10)
0.5 x 2 points	2.3	2.1	1.9	1.7	1.5	1.2	1.1	0.9
1.0 x 2 points	9.2	8.5	7.7	6.9	6.0	4.9	4.2	3.5
1.2 x 2 points	13.2	12.2	11.2	10.0	8.6	7.1	6.1	5.0
1.4 x 2 points	18.0	16.6	15.2	13.6	11.8	9.6	8.3	6.8
1.6 x 2 points	23.5	21.7	19.8	17.7	15.4	12.5	10.9	8.9
1.8 x 2 points	29.7	27.5	25.1	22.5	19.4	15.9	13.7	11.2
2.0 x 2 points	36.7	33.9	31.0	27.7	24.0	19.6	17.0	13.9
2.5 x 2 points	57.3	53.0	48.4	43.3	37.5	30.6	26.5	21.7
3.0 x 2 points	82.5	76.4	69.7	62.4	54.0	44.1	38.2	31.2

Note) The above flow rate are calculated based on inlet pressure with no reference to pressure loss from pump to nozzle.

Instructions

Please read the “Product Manual” carefully and understand it completely before you use this product.

●Coolant fluid

1. In case of using water-soluble coolant, the fluid concentration should be 2% or more.

(Dilution ratio less than 50 times)

2. The cleanliness of coolant should be filtered by 20~30 μ m filter.

●Operating instructions

1. Make sure enough amount of coolant fluid is applied in the tank.

Before starting up, please check to see no foam in coolant fluid that might be generated by pouring.

2. Try activating the motor to check the rotating direction.

It should turn right (clockwise) when you view from the motor fan.

3. At initial testing or after pump change, inch the motor a couple of times (=activate the motor intermittently) in order to fill the pump with coolant fluid.

Activate the motor for 0.5 to 1 second each time for inching.

4. Please contact us for disassembly and re-assembly.

5. **E3P relief valve pressure is set to no load at a time of delivery. Please adjust the pressure to match the conditions for use.**

Turn the pressure adjustment screw to right (clockwise) to increase pressure.